



ENGINES

MARINE DIESEL ENGINE SV-230

BASED ON VM - 6 CYLINDERS 230 HP.

TURBO
Intercooler



General characteristics

This modern diesel marine engine is outstandingly rugged, reliable, with a compact size, low weight and a great power delivery, that make the engine highly versatile, for use in recreational vessels.

Combustion system

The direct injection system with rotative injector pump, and mechanical regulator provide low consumption and high performance across the range of revolutions, as well as a low level of noise and vibrations.

Cooling system

The fresh-water cooling system based on a thermostatically controlled valve and heat exchanger keeps engine temperature constant at any rpm.

Electrical system

The electrical system is 12 V, with a 70 Amp. alternator and built-in electronic regulator. A comprehensive control panel with sound alarms protects the engine efficiently from any possible incident.

The electrical system is mounted on the engine, with an oil pressure gauge and a cooling liquid temperature thermometer.

Gearbox

The high performance hydraulic gearbox makes it possible to mount both right and left spin propellers. The motor can be supplied with other gearbox types to suit customer requirements.

SV-230

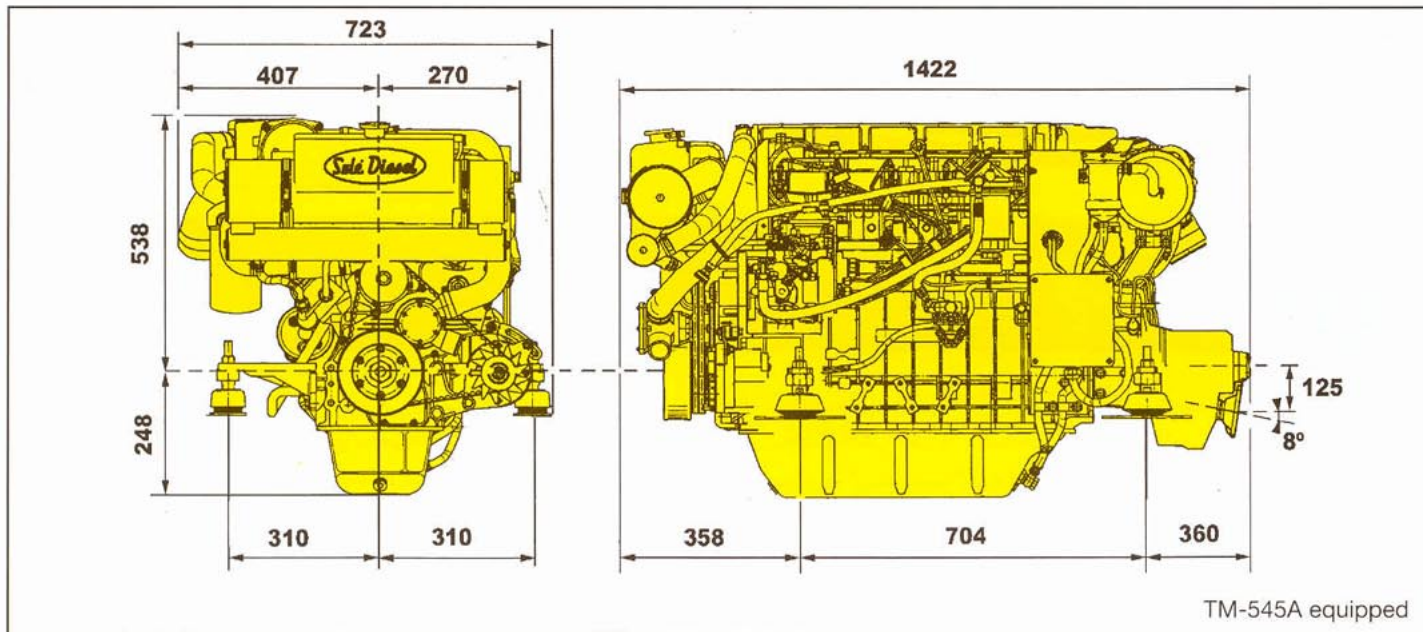

TM-545A equipped

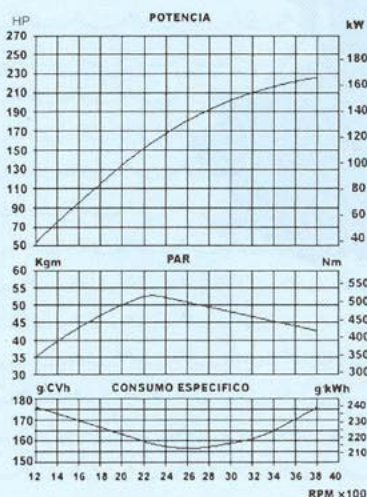

SPECIFICATIONS

Type	Diesel , 4 stroke, turbo-intercooler
Nº of cylinders	6 in line
Bore x stroke mm (in)	94 x 100 (3.70 x 3.93)
Total displacement cc. (cu. in.)	4164 (254)
Compression ratio	17:1
Max. Output intern ISO 3046/1	230HP (169 kW)
Max speed (r.p.m.)	3800
Injection system	Direct
Cooling system	Coolant heat exchanger with water cooled exhaust manifold.
Electrical system	12V. Starter motor 3 kW. 70 Amp. alternator
Gearbox (Hydraulic)	TECHNODRIVE TM 545A
Reduction ratio	1'5:1, 2'09:1.
Weight with hydraulic gearbox Kg (lbs.)	465 (1026.4)
Installation angle	15° continuous- Intermittent 20°

Standard equipment:

Electrical starter and alternator, electric stop, control panel with tachometer, hour counter, starter switch, water temperature gauge, audible alarm for oil and water, oil pressure gauge and voltmeter. Oil filter, cooled exhaust manifold, flexible mountings, 4 mts wirings and connection kit for control cables.

Optional equipment:

Water filter, fuel filter with water separator, remote engine control, propeller shaft, stern tube and propellers.

Specifications are subject to change without prior notice.

Importer:

Dealer:

Tous les articles présentés sont en vente chez :

Léon Marine – 34200 Sète

Tel 04 67 74 34 60 – Fax 04 67 74 85 16

<http://www.leon-marine.com>